

REGOLATORE LIVELLO OLIO MECCANICO -REGOLABILE-/ MECHANICAL ADJUSTABLE OIL LEVEL REGULATOR

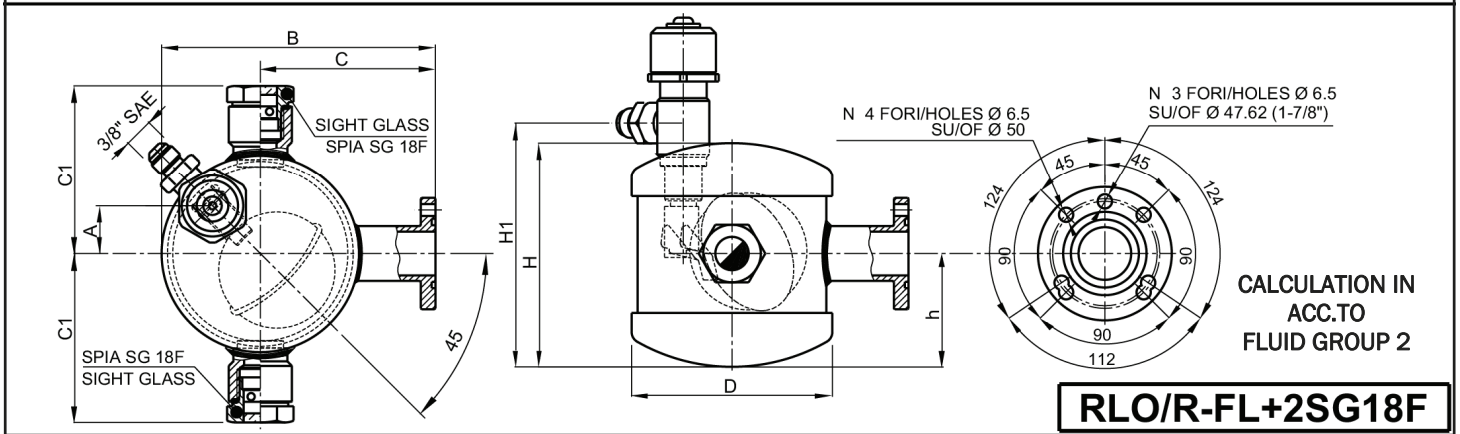
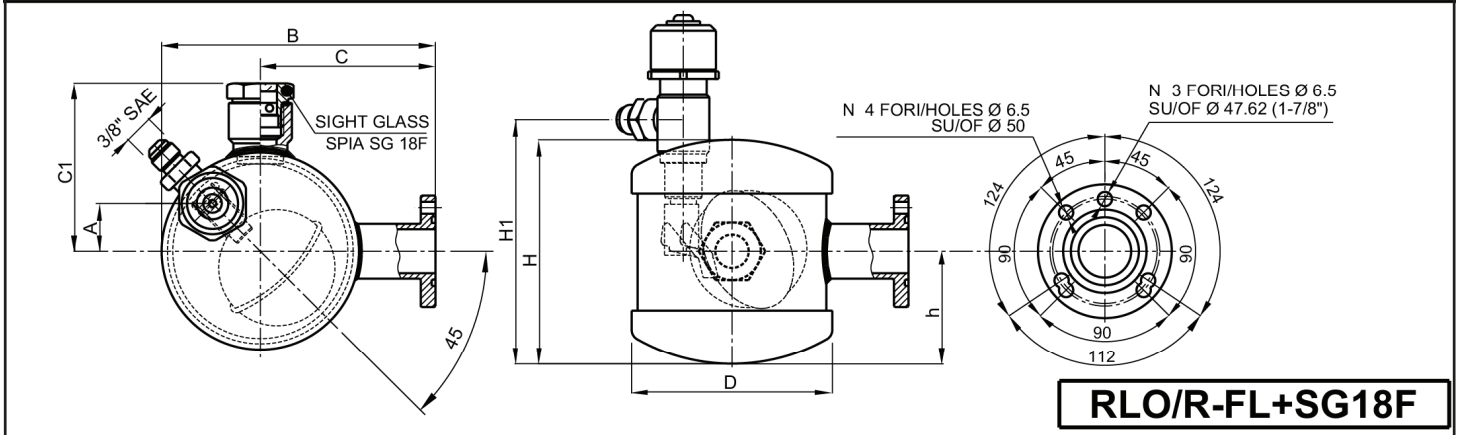
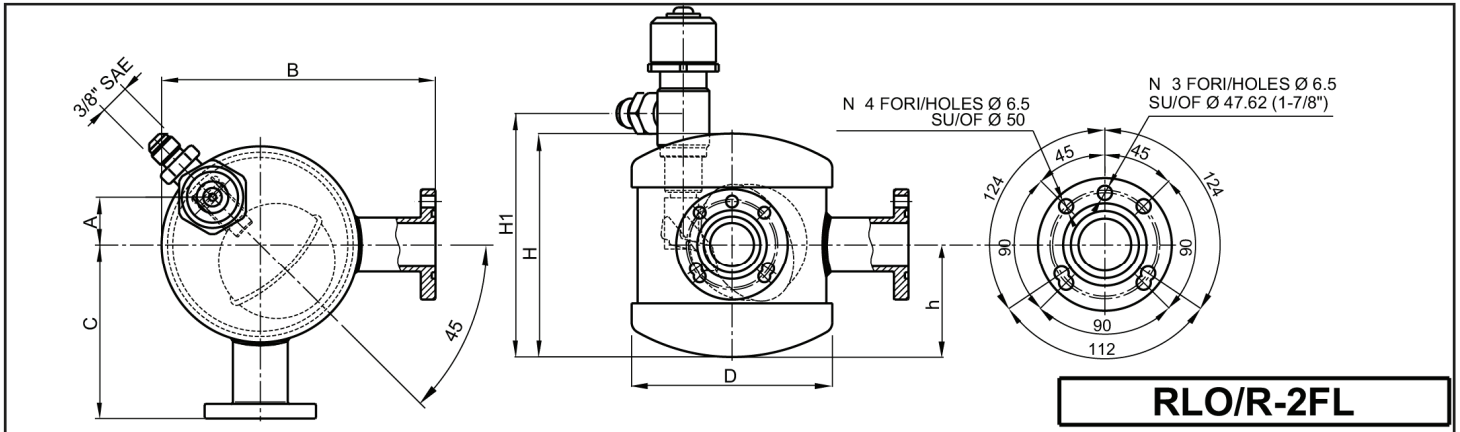

DATI TECNICI, TECHNICAL DATA

Temperatura TS - °C Temperature TS - °C	Min. -10 Max. +140	Min. -50 Max. +140	Pressione di collaudo PT Test pressure PT
Pressione max. consentita PS-bar Max permissible pressure PS-bar	31	23	PT-bar: 34 (31x1.1)

NOTE: E' possibile fornire tutti i modelli con pressione massima di esercizio fino a 45 bar / It is possible to supply all models with max working pressure till 45 bar

Refrigerants: HCFC-HFC-HFO-HC ,CO₂ and other ones with low GWP

PED CAT.	TIPO / TYPE	VOLUME litri litres	DIMENSIONI / DIMENSIONS								LIVELLO OLIO REGOLABILE OIL LEVEL ADJUSTABLE	Pressione differenziale di lavoro permessa (bar) Allowable differential oil pressure (bar)	Pressione differenziale raccomandata (bar) Recommended differential oil pressure (bar)
			D	H1	H	h	A	B	C	C1			
Art.4§3	RLO/R-2FL	0.70	108	132	121	61	26	140	86	/	1/2 SIGHT GLASS	0.35 ÷ 6.5	1.4
	RLO/R-FL+SG18F	0.70	108	132	121	61	26	140	86	95	OIL LEVEL -3 ÷ +6 mm		
	RLO/R-FL+2SG18F	0.70	108	132	121	61	26	140	86	95			